

G Rotary Unions

For coolant, water, oil and air service

KADANT
AN ACCENT ON INNOVATION

Precision rotary unions
for more effective
cooling and lubrication.

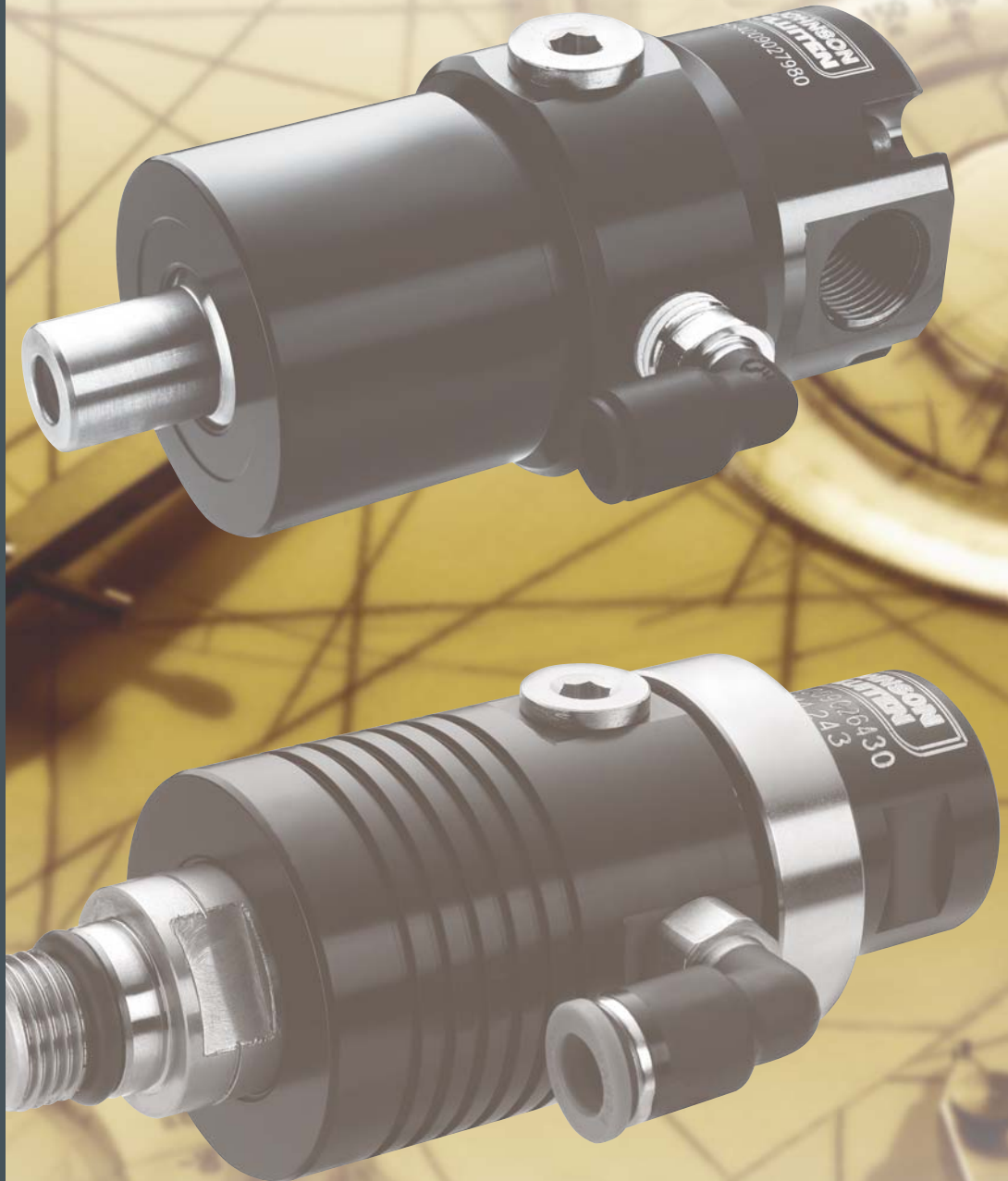

High speed rotating unions for transferring fluids and air.

Contents

Type G Rotary Union Overview	3
GA General Purpose Air and Hydraulic Unions	4
GAI Internal Mounted Unions	5
GR/GRA Coolant Unions for Horizontal Installations	6
GL/GLA Low Filtration, High Speed Coolant Unions	7
GFL/GFLA Coolant Unions for Dry Running	8
GFS/GFSA Coolant Unions for Dry Running	9
GB High Pressure Water and Hydraulic Unions	10
G5050 Bearingless Coolant Unions	11
GHP/GHPA Unions	12
GHS/GHSA Unions	13
Bracket Mounted	14
Custom Unions	16
Multi-Passage Air and Hydraulic Unions	17
Multi-Purpose Air and Hydraulic Unions	18
Recommendations	19

Quick Select Chart

Type	Media			Pressure (Max.)		Temperature (Max.)		Speed (RPM)
	Coolant	Air	Oil	BAR	PSI	°C	°F	
GA	●	●	●	105	1.500	120	250	6.000
GAI	●	●	●	70	1.000	120	250	3.500
GB	●	●	●	400	5.800	90	195	1.500
GR/GRA	●	● (1)	●	70	1.000	90	195	10.000
GL/GLA	●	● (1)	●	110	1.595	90	195	15.000
GFL/GFLA	●	●	●	80	1.160	90	195	15.000
GFS/GFSA	●	●	●	80	1.160	90	195	20.000
GHP	●	●	●	140	2.030	90	195	32.000
GHS	●	●	●	80	1.160	90	195	42.000
G5050	●	●	●	105	1.500	120	250	30.000
G2M/G4M/G5M	●	●	●	250	3.610	90	195	100
G4888	●	●	●	250	3.610	90	195	100
G5007	●	●	●	70	1.000	120	250	1.500
Bracket Mounted	●	● (1)	●	80	1.160	120	250	24.000

- Recommended
- Acceptable
- Not Recommended

1. Consult the factory for specific details.
2. For specific application parameters, see catalogue page. Higher speed and pressure available on request.
3. Do not operate unions at a combination maximum values of pressure, temperature, and speed.

Overview

The Type G rotary union is a high performance, high precision union for coolant, air, and hydraulic oil applications. Type G unions are generally applied to the machine tool industry for:

- ▶ Transfer lines
- ▶ Gun drills
- ▶ Spindles
- ▶ Drilling
- ▶ Milling
- ▶ Rotary index tables
- ▶ Machine tools
- ▶ CNC machines
- ▶ Grinding machines
- ▶ Presses
- ▶ Clutches

Based on more than 40 years of mechanical seal design and application expertise, the Type G rotary union line is built to perform under the most demanding conditions. A thorough understanding of seal load optimisation, seal wear characteristics, and application knowledge means the Type G union can provide years of reliable service for coolant, air, and hydraulic oil applications.



Precision rotary unions designed for smooth running, high speed coolant, air, and hydraulic oil applications.

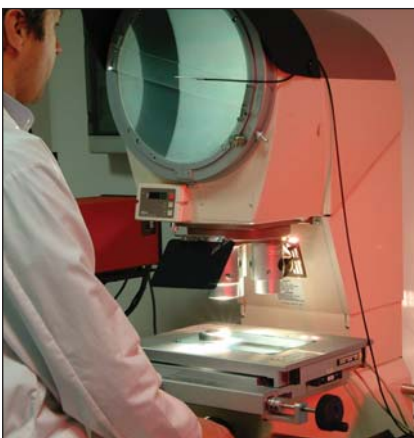

Measuring and controlling seal design ensures leak-free operation.

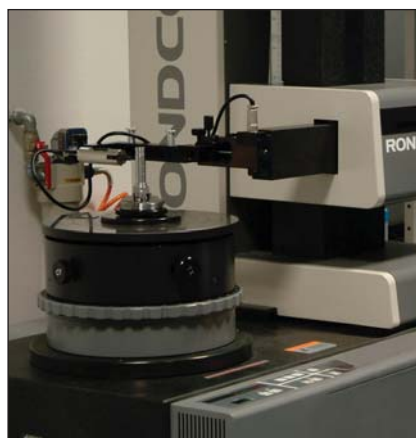

Rotor concentricity is measured to allow vibration-free operation.



Laser etched hydrodynamic grooves provide improved seal performance.

Type GA

GA

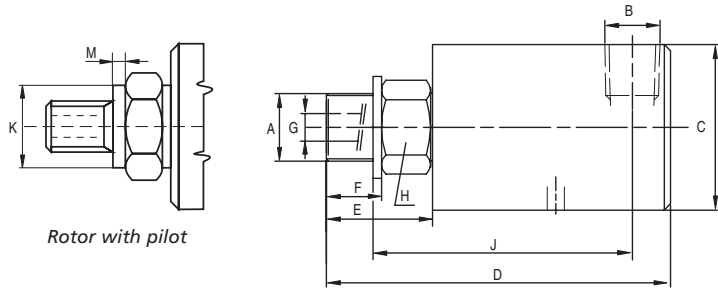

Type	A	B	C	D	E	F	G	H	J	K	M	Weight (Kg)	
GA003002503	M10 X 1	RH	1/8" NPT	31	72	22	11	3,2	17	54	-	-	0,15
GA003002505	M10 X 1	RH	1/8" NPT	31	72	22	11	3,2	17	54	11 ⁰ _{-0,011}	3	0,15
GA003002504	G 1/4" (BSP)	RH	1/8" NPT	31	72	22	13	3,2	17	52	-	-	0,15
GA006015830	1/4" NPT	RH	1/4" NPT	39	82	26	17	6,5	22	58	-	-	0,5
GA006000594	5/8" - 18 UNF	RH	1/4" NPT	39	81	25	16	6,5	22	58	-	-	0,5
GA006003592	5/8" - 18 UNF	LH	1/4" NPT	39	81	25	16	6,5	22	58	-	-	0,5
GA006002506	G 1/4" (BSP)	RH	1/4" NPT	39	81	25	13	6,5	22	61	-	-	0,5
GA006002507	G 1/4" (BSP)	LH	1/4" NPT	39	81	25	13	6,5	22	61	-	-	0,5
GA009015831	3/8" NPT	RH	3/8" NPT	44	101	27	17	8,5	22	72,5	-	-	0,5
GA009002510	5/8" - 18 UNF	RH	3/8" NPT	44	100	26	16	8,5	22	72,5	-	-	0,5
GA009003594	5/8" - 18 UNF	LH	3/8" NPT	44	100	26	16	8,5	22	72,5	-	-	0,5
GA009000601	G 3/8" (BSP)	RH	3/8" NPT	44	100	26	16	8,5	22	72,5	-	-	0,5
GA009003593	G 3/8" (BSP)	LH	3/8" NPT	44	100	26	16	8,5	22	72,5	-	-	0,5
GA009001590	M16 X 2	RH	3/8" NPT	44	100	26	16	8,5	22	72,5	-	-	0,5
GA012015832	1/2" NPT	RH	1/2" NPT	59	118	37	22	13	36	86	-	-	0,7
GA012001248	3/4" - 16 UNF	RH	1/2" NPT	59	115	34	19	13	36	86	-	-	0,7
GA012003596	3/4" - 16 UNF	LH	1/2" NPT	59	115	34	19	13	36	86	-	-	0,7
GA012002217	G 1/2" (BSP)	RH	1/2" NPT	59	115	34	19	13	36	86	-	-	0,7
GA012003597	G 1/2" (BSP)	LH	1/2" NPT	59	115	34	19	13	36	86	-	-	0,7
GA012002316	G 3/4" (BSP)	RH	1/2" NPT	59	115	34	19	13	36	86	-	-	0,7
GA012003598	G 3/4" (BSP)	LH	1/2" NPT	59	115	34	19	13	36	86	-	-	0,7
GA012003595	M20 X 1,5	RH	1/2" NPT	59	115	34	19	13	36	86	22 ^{-0,007} _{-0,020}	5	0,7
GA012003599	M20 X 1,5	LH	1/2" NPT	59	115	34	19	13	36	86	22 ^{-0,007} _{-0,020}	5	0,7
GA012002431	M22 X 1,5	RH	1/2" NPT	59	115	34	19	13	36	86	27 ^{-0,007} _{-0,020}	3	0,7
GA012003600	M22 X 1,5	LH	1/2" NPT	59	115	34	19	13	36	86	27 ^{-0,007} _{-0,020}	3	0,7

Consult factory for additional thread type.

Fluid	Pressure (BAR)	Temperature (°C)	RPM	RPM (with pilot)
Air	10	120	1.500	1.500
Coolant	70	120	3.500	6.000
Hydraulic Oil	105	120	3.500	6.000

Features and Benefits

- ▶ Precision ball bearings lubricated for life
- ▶ Hardened stainless steel rotor
- ▶ Optimised seal balance ratio for minimal friction
- ▶ Smooth running, no vibration
- ▶ Body available in anodised aluminum or brass
- ▶ Stationary seal face available in carbon graphite, bronze seal face for hydraulic oil above 70 bar

Type GAI

GAI

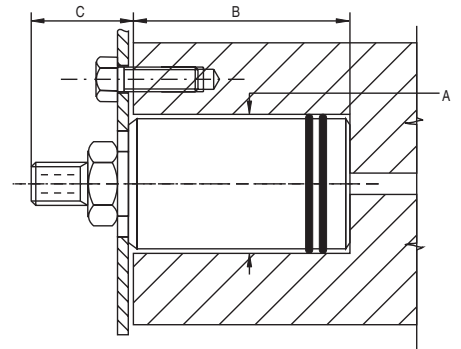

Type	Rotor	A ⁺	B	C	Weight (Kg)
GAI003002516	M10 X 1 RH	31	48	24	0,15
GAI003002515	G 1/4" (BSP) RH	31	48	24	0,15
GAI006001215	5/8" - 18 UNF RH	39	54	27	0,5
GAI006003601	5/8" - 18 UNF LH	39	54	27	0,5
GAI006002372	G 1/4" (BSP) RH	39	54	27	0,5
GAI006003602	G 1/4" (BSP) LH	39	54	27	0,5
GAI009002780	5/8" - 18 UNF RH	44	72	28	0,5
GAI009003604	5/8" - 18 UNF LH	44	72	28	0,5
GAI009000824	G 3/8" (BSP) RH	44	72	28	0,5
GAI009003603	G 3/8" (BSP) LH	44	72	28	0,5
GAI009001380	M16 X 2 RH	44	72	28	0,5
GAI012000640	3/4" - 16 UNF RH	59	78	37	0,7
GAI012003605	3/4" - 16 UNF LH	59	78	37	0,7
GAI012003477	G 1/2" (BSP) RH	59	78	37	0,7
GAI012003607	G 1/2" (BSP) LH	59	78	37	0,7
GAI012001419	G 3/4" (BSP) RH	59	78	37	0,7
GAI012003606	G 3/4" (BSP) LH	59	78	37	0,7

+ Dimension tolerance is +0,3/+0,4

Fluid	Pressure (BAR)	Temperature (°C)	RPM
Air	10	120	1.500
Coolant	70	120	3.500
Hydraulic Oil	70	120	3.500

Features and Benefits

- ▶ Compact design mounted inside shaft
- ▶ Hardened stainless steel rotor
- ▶ Optimised seal balance ratio for minimal friction
- ▶ Available with non-contacting seal ring with hydrodynamic grooves
- ▶ Anodised aluminum body

Type GR/GRA

GR

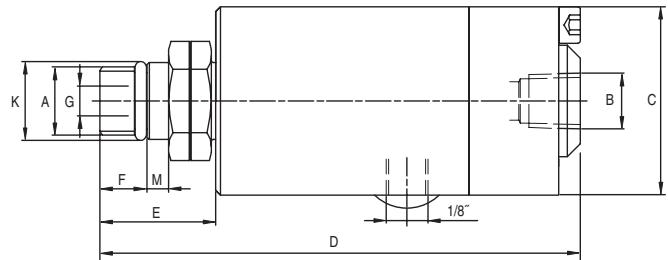

Type	A	B	C	D	E	F	G	K	M	X	Y	Z	Weight (Kg)
GR006016050	M16 X 1,5 LH	1/4" NPT	44	112	27	11	7	17,994/17,983	5	18,007/17,997	8,5	17	0,4
GR006016052	5/8" - 18 UNF RH	1/4" NPT	44	115	30	14	7	16,650/16,645	5	16,662/16,652	8,5	20	0,4
GR006016053	5/8" - 18 UNF LH	1/4" NPT	44	115	30	14	7	16,650/16,645	5	16,662/16,652	8,5	20	0,4

GRA

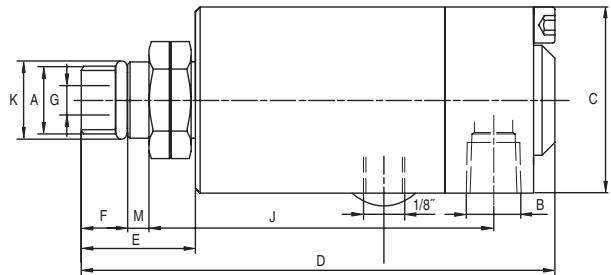

Type	A	B	C	D	E	F	G	J	K	M	X	Y	Z	Weight (Kg)
GRA009016057	M16 X 1,5 LH	3/8" NPT	44	112	27	11	7	81,5	17,994/17,983	5	18,007/17,997	8,5	17	0,4
GRA009016060	5/8" - 18 UNF RH	3/8" NPT	44	115	30	14	7	81,5	16,650/16,645	5	16,662/16,652	8,5	20	0,4
GRA009016061	5/8" - 18 UNF LH	3/8" NPT	44	115	30	14	7	81,5	16,650/16,645	5	16,662/16,652	8,5	20	0,4

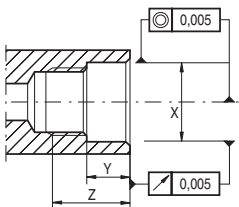

Spindle Detail

Type	Pressure (BAR)	Temperature (°C)	RPM
GR/GRA006	70	90	10.000
GR/GRA009	70	90	10.000

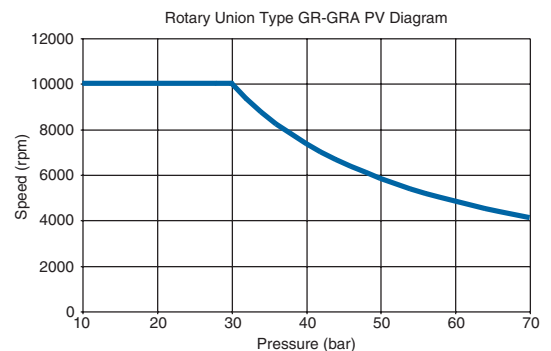

Features and Benefits

- ▶ Labyrinth seal and drain holes protect bearings
- ▶ Optimised seal balance ratio
- ▶ Tungsten carbide seal faces resist wear and thermal shock
- ▶ Precision ball bearings eliminate vibration
- ▶ Anodised aluminum body
- ▶ Full flow area, minimal pressure drop
- ▶ Multiple stainless steel springs located outside the flow
- ▶ Stainless steel rotor resists corrosion

Type GL/GLA

GL

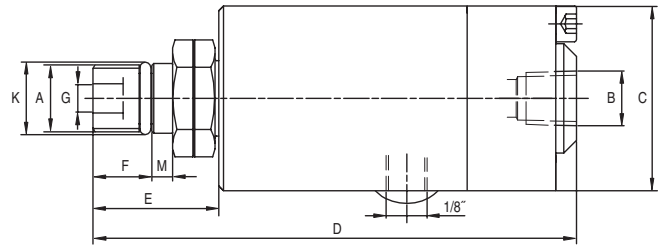

Type	A	B	C	D	E	F	G	K	M	X	Y	Z	Weight (Kg)
GL006015720	M16 X 1,5 LH	1/4" NPT	44	112	27	11	7	17,994/17,983	5	18,007/17,997	8,5	17	0,4
GL006015676	5/8" - 18 UNF RH	1/4" NPT	44	115	30	14	7	16,650/16,645	5	16,662/16,652	8,5	20	0,4
GL006015675	5/8" - 18 UNF LH	1/4" NPT	44	115	30	14	7	16,650/16,645	5	16,662/16,652	8,5	20	0,4

GLA

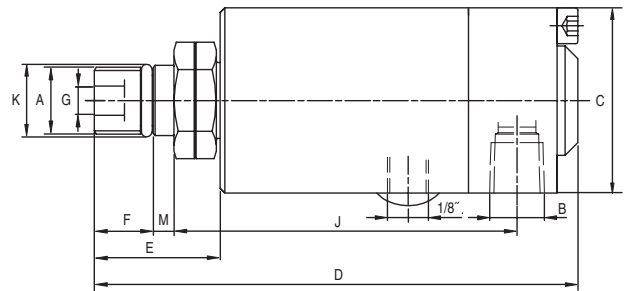

Type	A	B	C	D	E	F	G	J	K	M	X	Y	Z	Weight (Kg)
GLA009015723	M16 X 1,5 LH	3/8" NPT	44	112	27	11	7	81,5	17,994/17,983	5	18,007/17,997	8,5	17	0,4
GLA009015682	5/8" - 18 UNF RH	3/8" NPT	44	115	30	14	7	81,5	16,650/16,645	5	16,662/16,652	8,5	20	0,4
GLA009015681	5/8" - 18 UNF LH	3/8" NPT	44	115	30	14	7	81,5	16,650/16,645	5	16,662/16,652	8,5	20	0,4
GLA009019953*	M16 X 1,5 LH	3/8" NPT	44	112	27	11	7	81,5	17,994/17,983	5	18,007/17,997	8,5	17	0,4

* Dry run at atmospheric pressure possible.

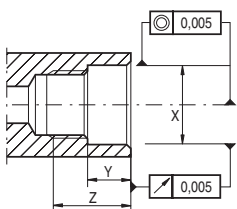

Spindle Detail

Type	Pressure (BAR)	Temperature (°C)	RPM
GL/GLA006	110	90	15.000
GL/GLA009	110	90	15.000

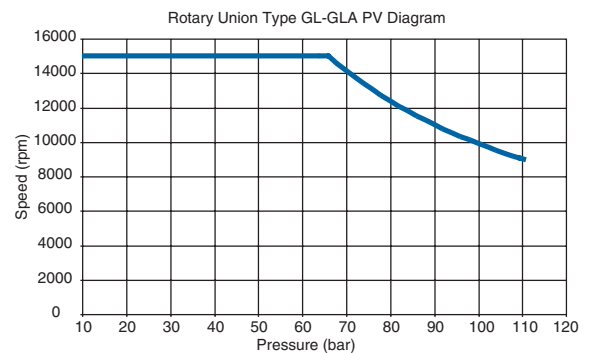

Features and Benefits

- ▶ Labyrinth seal and drain holes protect bearings
- ▶ Optimised seal balance ratio
- ▶ Tungsten carbide seal faces resist wear and thermal shock
- ▶ Angular ball bearing design resists side loading
- ▶ Anodised aluminum body
- ▶ Full flow area, minimal pressure drop
- ▶ Multiple stainless steel springs located outside the flow
- ▶ Stainless steel rotor resists corrosion

Type GFL/GFLA

Dry running

GFL

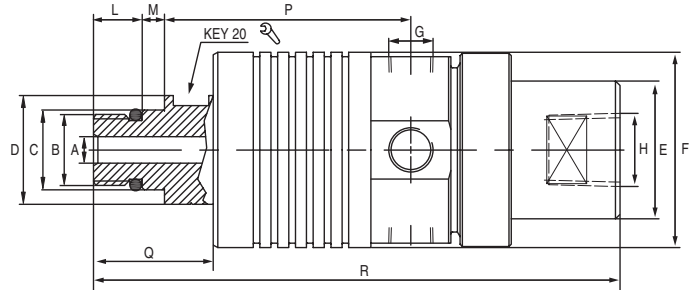

Type	A	B	C	D	E	F	G	H	L	M	P	Q	R	Weight (Kg)
GFL009028400	6	M16 X 1,5 LH	18g6	24,5	31	44	1/8" BSP	3/8" BSP	11	5	55,5	27	118,6	0,50
GFL009028401	6	5/8" - UNF LH	16,650/16,645	24,5	31	44	1/8" BSP	3/8" NPT	14	5	55,5	30	121,6	0,50

GFLA

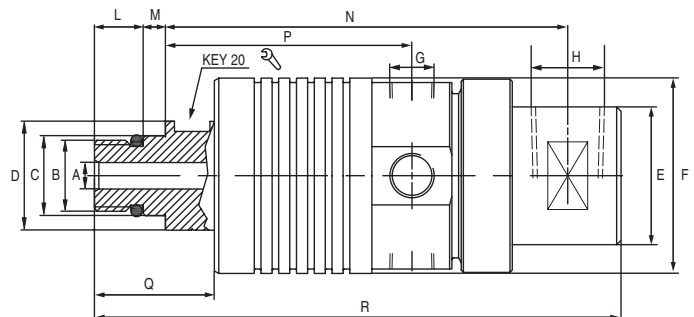

Type	A	B	C	D	E	F	G	H	L	M	N	P	Q	R	Weight (Kg)
GFLA009028405	6	M16 X 1,5 LH	18g6	24,5	31	44	1/8" BSP	3/8" BSP	11	5	90,6	55,5	27	118,6	0,50
GFLA009028406	6	5/8" - UNF LH	16,650/16,645	24,5	31	44	1/8" BSP	3/8" NPT	14	5	90,6	55,5	30	121,6	0,50

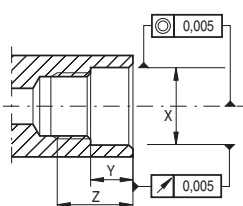

Spindle Detail

Fluid	Pressure (BAR)	Temperature (°C)	RPM
Coolant	80	90	15.000
Air	5 maximum	90	10.000

Rotary Union Type GFL-GFLA PV Diagram

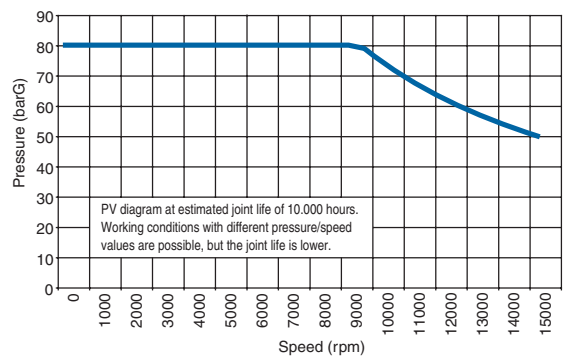

Features and Benefits

- ▶ Special seal design permits dry running
- ▶ Optimised seal balance ratio for minimal friction
- ▶ Precision angular contact bearings widely spaced to eliminate wobble and vibration
- ▶ Labyrinth seal and drain holes protect bearings
- ▶ Anodised aluminum body
- ▶ Reduced coolant misting for improved air quality
- ▶ Low heat generation in bearings and mechanical seal
- ▶ No leakage during tool change commutation
- ▶ Low vibration for precise machining
- ▶ Also available for rotation with compressed air
- ▶ Supplied with bearings run-in upon request
- ▶ Closing ring suitable for proximity sensing drawbar position

Type GFS/GFSA

Dry running

GFS

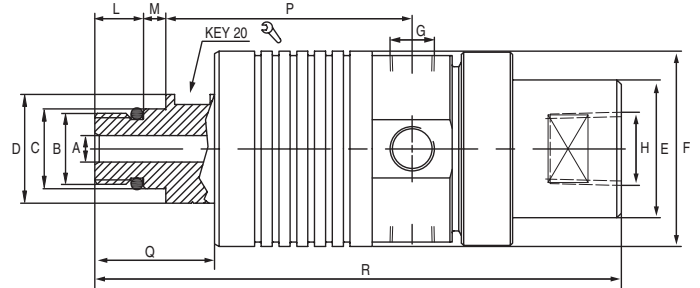

Type	A	B	C	D	E	F	G	H	L	M	P	Q	R	Weight (Kg)
GFS009028410	6	M16 X 1,5 LH	18g6	24,5	31	44	1/8" BSP	3/8" BSP	11	5	55,5	27	118,1	0,50
GFS009028411	6	5/8" - UNF LH	16,650/16,645	24,5	31	44	1/8" BSP	3/8" NPT	14	5	55,5	30	121,1	0,50

GFSA

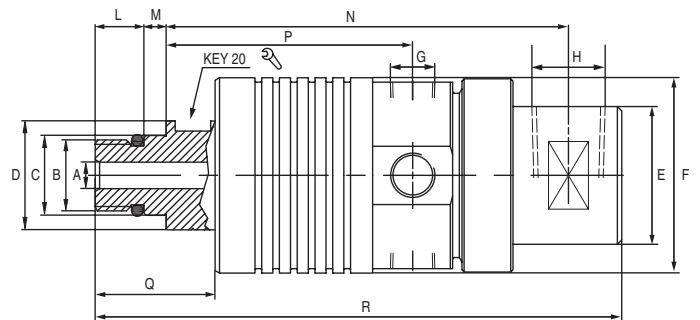

Type	A	B	C	D	E	F	G	H	L	M	N	P	Q	R	Weight (Kg)
GFSA009028415	6	M16 X 1,5 LH	18g6	24,5	31	44	1/8" BSP	3/8" BSP	11	5	90,1	55,5	27	118,1	0,50
GFSA009028416	6	5/8" - UNF LH	16,650/16,645	24,5	31	44	1/8" BSP	3/8" NPT	14	5	90,1	55,5	30	121,1	0,50

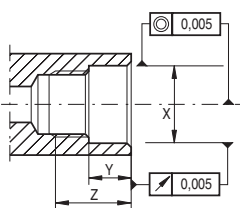

Spindle Detail

Fluid	Pressure (BAR)	Temperature (°C)	RPM
Coolant	80	90	20.000
Air	5 maximum	90	10.000

Rotary Union Type GFS-GFSA PV Diagram

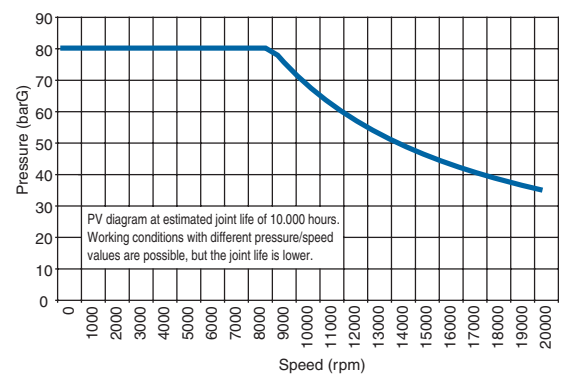

Features and Benefits

- ▶ Special seal design permits dry running
- ▶ Optimised seal balance ratio for minimal friction
- ▶ High precision angular contact bearings eliminate wobble and vibration
- ▶ Labyrinth seal and drain holes protect bearings
- ▶ Anodised aluminum body
- ▶ High speed, dry run applications
- ▶ Reduced coolant misting for improved air quality
- ▶ Low heat generation in bearings and mechanical seal
- ▶ No leakage during tool change commutation
- ▶ Low vibration for precise machining
- ▶ Also available for rotation with compressed air
- ▶ Supplied with bearings run-in upon request
- ▶ Closing ring suitable for proximity sensing drawbar position

Type GB

GB

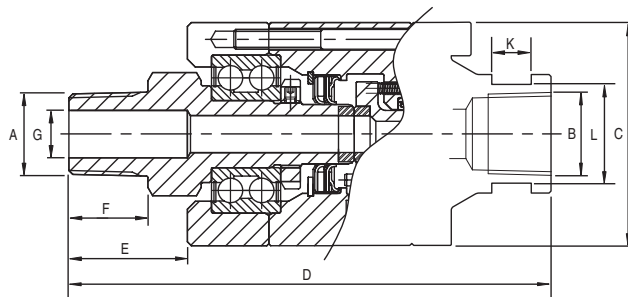

Type	A	B	C	D	E	F	G	K	L	Weight (Kg)
GB006018350	1/4" NPT RH	1/4" NPT	57	117	25	15	7	10	25	0,90
GB006018351	1/4" NPT LH	1/4" NPT	57	117	25	15	7	10	25	0,90
GB006018352	1/4" BSP RH	1/4" BSP	57	117	25	15	7	10	25	0,90
GB006018353	1/4" BSP LH	1/4" BSP	57	117	25	15	7	10	25	0,90
GB009018354	3/8" NPT RH	3/8" NPT	57	117	25	15	10	10	25	0,90
GB009018355	3/8" NPT LH	3/8" NPT	57	117	25	15	10	10	25	0,90
GB009018356	3/8" BSP RH	3/8" BSP	57	117	25	15	10	10	25	0,90
GB009018357	3/8" BSP LH	3/8" BSP	57	117	25	15	10	10	25	0,90
GB012018358	1/2" NPT RH	1/2" NPT	57	122	30	20	12	10	25	0,90
GB012018359	1/2" NPT LH	1/2" NPT	57	122	30	20	12	10	25	0,90
GB012018360	1/2" BSP RH	1/2" BSP	57	122	30	20	12	10	25	0,90
GB012018361	1/2" BSP LH	1/2" BSP	57	122	30	20	12	10	25	0,90

Fluid	Pressure (BAR)	Temperature (°C)	RPM
Water	400	90	1.500
Hydraulic Oil	400	90	1.500

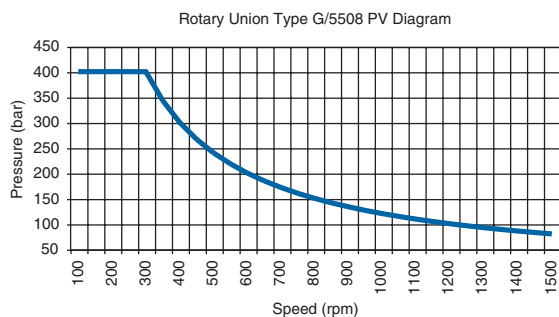

Features and Benefits

- ▶ Stainless steel rotor
- ▶ Labyrinth seal between bearing and mechanical seals for longer lifetime and safety
- ▶ Rigid bearing installation for safety
- ▶ Optimised seal balance for minimal friction
- ▶ Stainless steel and aluminum body
- ▶ All materials in contact with medium are non-corrosive

Type G5050

G5050

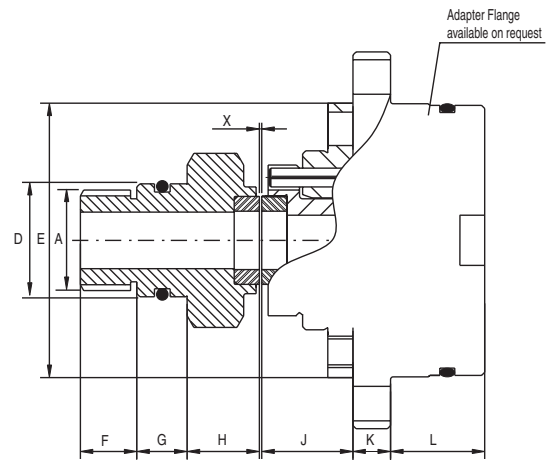

Type	A	D	E	F	G	H	J	K	L	X	Weight (Kg)
GX009014642	M16 X 1,5	18,007/17,997	44	9	8	12	15	6	15	0,2 – 1,0 mm	0,3

Pressure (BAR)	Temperature (°C)	RPM
105	120	30.000

Features and Benefits

- ▶ High speed bearingless coolant union
- ▶ External bracket-supported for speeds up to 30.000 RPM
- ▶ Auto-Off™ seal device option permits dry running
- ▶ Stainless steel body mounted on stationary surface
- ▶ Stub rotor mounted directly onto the spindle end
- ▶ Compact, precision design for installation flexibility
- ▶ Tungsten carbide seal faces resist wear and thermal shock
- ▶ Reduced coolant misting for improved air quality
- ▶ Custom designed rotary unions with housing or housing-less options
- ▶ Stroke between stationary and rotary components up to 1 mm
- ▶ High pressure design up to 150 bar – 75.000 rpm available



Custom-designed precision unions are available with laser-etched hydrodynamic grooves to provide improved seal life.

Type GHP/GHPA

GHP

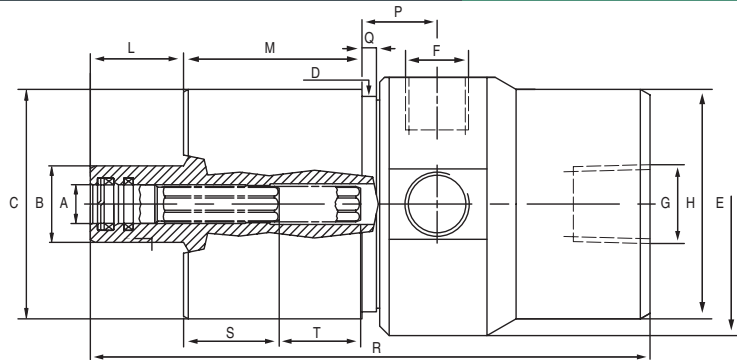

Type	A	B	C	D	E	F	G	H	L	M	P	Q	R	S	T	Weight (Kg)
GHP009	8g6	16	48/h7	45	55	1/4" BSP	3/8" BSP	48	19,5	37,3	15,7	3	117	20	17	0,60

GHPA

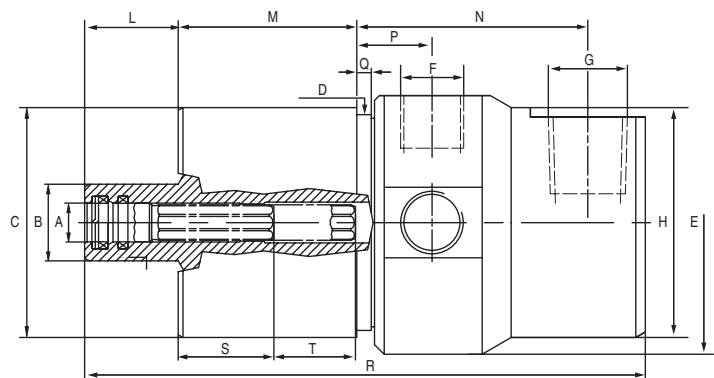

Type	A	B	C	D	E	F	G	H	L	M	N	P	Q	R	S	T	Weight (Kg)
GHPA009027981	8g6	16	48/h7	45	55	1/4" BSP	3/8" BSP	48	19,5	37,3	48,2	15,7	3	117	20	17	0,60

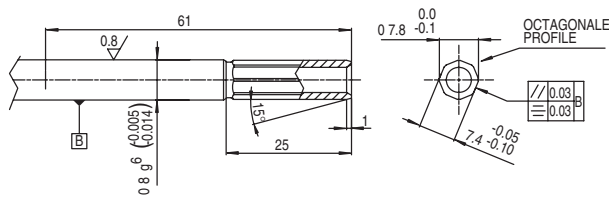

Type	Pressure (BAR)	Temperature (°C)	RPM
GHP/GHPA	150	90	24.000
High Speed	150	90	32.000

Fluid	Pressure (BAR)	Temperature (°C)	RPM
Air	5 maximum	90	10.000

Rotary Union Type GHP-GHPA PV Diagram

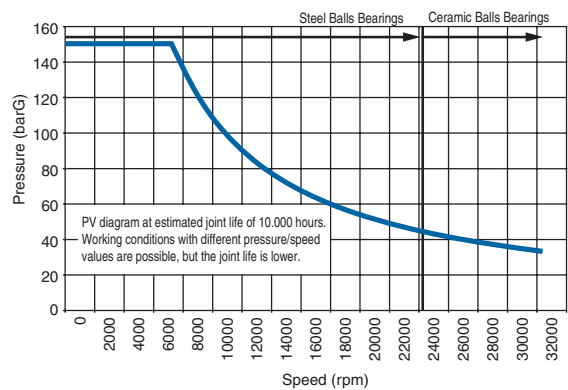

Features and Benefits

- ▶ Special seal design permits dry running
- ▶ Labyrinth seal and drain holes protect bearings
- ▶ Optimised seal balance ratio
- ▶ High precision angular contact bearings for high speeds
- ▶ Anodised aluminum body
- ▶ Full flow area, minimal pressure drop
- ▶ Long drawbar stroke for maximum flexibility
- ▶ Low heat generation in bearings and mechanical seal
- ▶ No leakage during tool change commutation
- ▶ Large drain holes to evacuate coolant from the union
- ▶ Supplied with bearings run-in upon request

Type GHS/GHSA

GHS

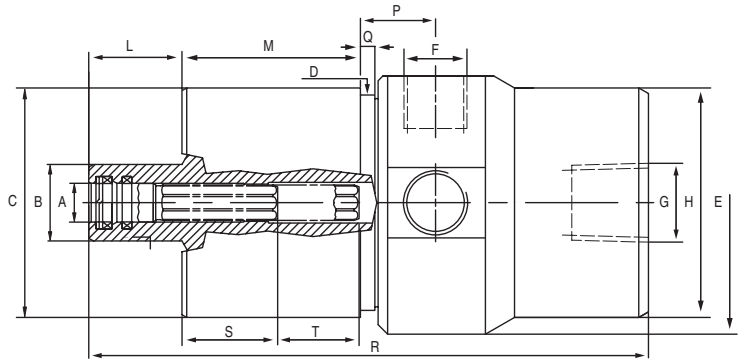

Type	A	B	C	D	E	F	G	H	L	M	P	Q	R	S	T	Weight (Kg)
GHS009	8g6	16	48/h7	45	55	1/4" BSP	3/8" BSP	48	19,5	37,3	15,7	3	117	20	17	0,60

GHSA

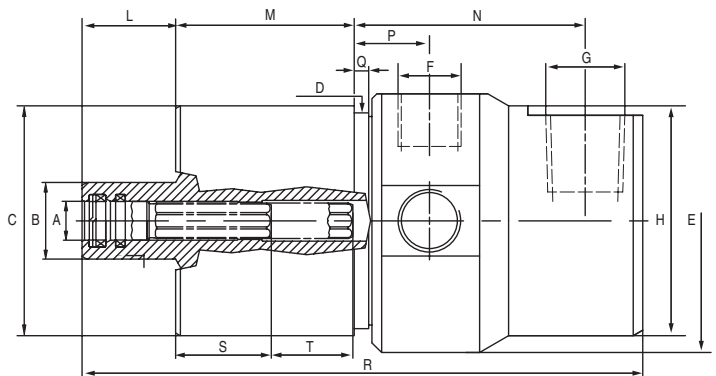

Type	A	B	C	D	E	F	G	H	L	M	N	P	Q	R	S	T	Weight (Kg)
GHSA009027980	8g6	16	48/h7	45	55	1/4" BSP	3/8" BSP	48	19,5	37,3	48,2	15,7	3	117	20	17	0,60

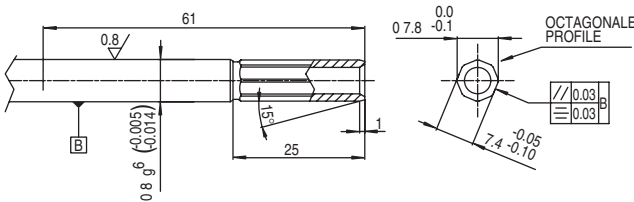

Type	Pressure (BAR)	Temperature (°C)	RPM
GHS/GHSA	80	90	32.000
High Speed	80	90	42.000

Fluid	Pressure (BAR)	Temperature (°C)	RPM
Air	5 maximum	90	10.000

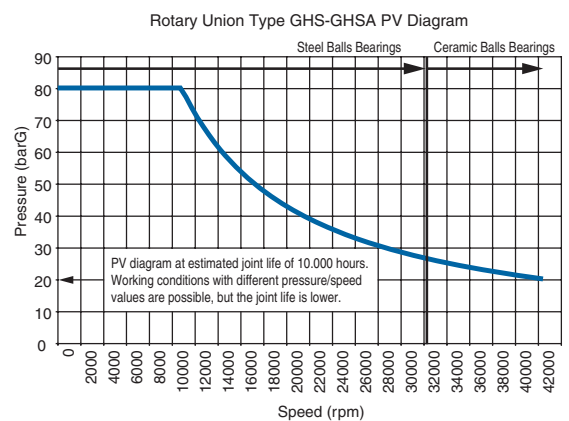

Features and Benefits

- ▶ Special seal design permits dry running
- ▶ Labyrinth seal and drain holes protect bearings
- ▶ Optimised seal balance ratio
- ▶ High precision angular contact bearings for high speeds
- ▶ Anodised aluminum body
- ▶ Full flow area, minimal pressure drop
- ▶ Long drawbar stroke for maximum flexibility
- ▶ Seal to protect bearings for air pressure in rotor area
- ▶ Low heat generation in bearings and mechanical seal
- ▶ No leakage during tool change commutation
- ▶ Large drain holes to evacuate coolant from the union
- ▶ Supplied with bearings run-in upon request

Bracket Mounted

G/5327

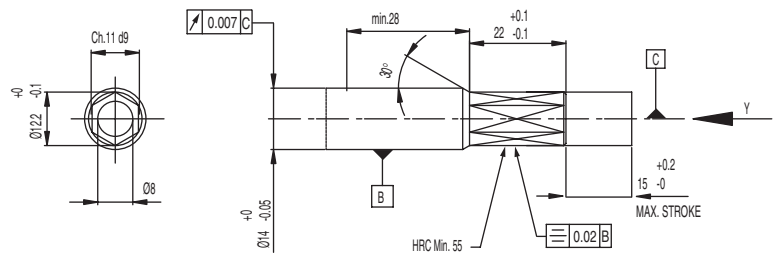
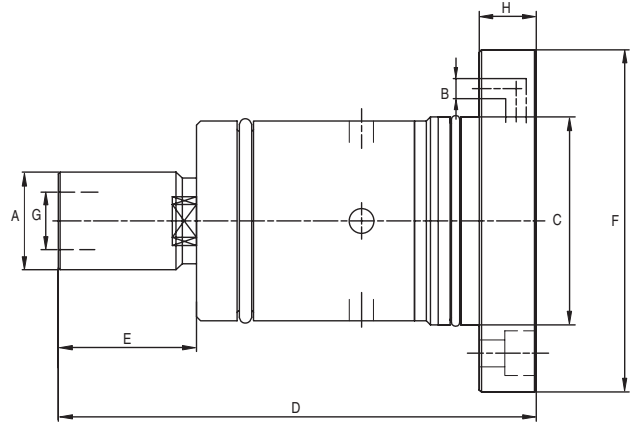

Type	A	B	C	D	E	F	G	H
G/5327	24	5	51 f7	117,5	34	84	14,1 H7	14

Type	Pressure (BAR)	Temperature (°C)	RPM
G/5327	70	90	18.000

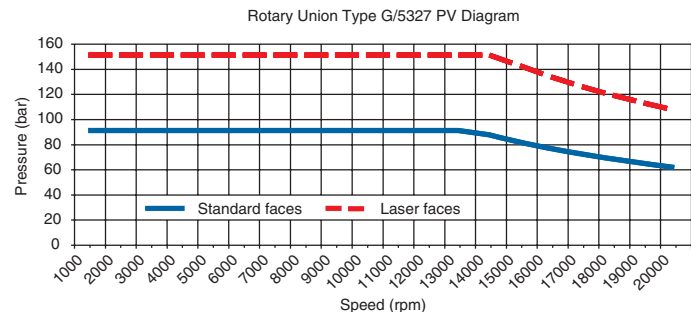

Features and Benefits

- ▶ Auto-Off™ seal device permits dry running
- ▶ Precision bearing for long lifetime
- ▶ Tungsten carbide seal faces resist wear and thermal shock
- ▶ Drawbar stroke 15 mm
- ▶ Coolant connection in flange for reduced hose load
- ▶ Anodised aluminum body

G10C

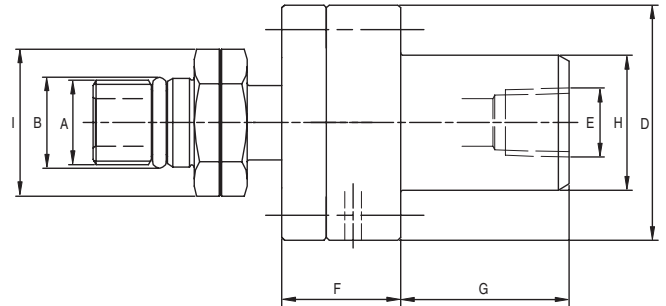

Type – without lip-seal	Type – with lip-seal	A	B	D	E	F	G	H	I
G10C006018362	G10C006018382	5/8" - 18 LH	16	44,2	1/4" NPT	22,35	31,75	34,95	23
G10C006018363	G10C006018383	5/8" - 18 RH	16	44,2	1/4" NPT	22,35	31,75	34,95	23
G10C006018364	G10C006018384	3/8" - 24 LH	10	44,2	1/4" NPT	22,35	31,75	34,95	23
G10C006018365	G10C006018385	3/8" - 24 RH	10	44,2	1/4" NPT	22,35	31,75	34,95	23
G10C006018366	G10C006018386	1/2" - 20 LH	13	44,2	1/4" NPT	22,35	31,75	34,95	23
G10C006018367	G10C006018387	1/2" - 20 RH	13	44,2	1/4" NPT	22,35	31,75	34,95	23
G10C006018368	G10C006018388	M16" X 1,5 LH	18	44,2	1/4" NPT	22,35	31,75	34,95	23
G10C006018369	G10C006018389	M16" X 1,5 RH	18	44,2	1/4" NPT	22,35	31,75	34,95	23
G10C006018370	G10C006018390	M10" X 1 LH	11	44,2	1/4" NPT	22,35	31,75	34,95	23
G10C006018371	G10C006018391	M10" X 1 RH	11	44,2	1/4" NPT	22,35	31,75	34,95	23
G10C006018372	G10C006018392	M12" X 1,25 LH	13	44,2	1/4" NPT	22,35	31,75	34,95	23
G10C006018373	G10C006018393	M12" X 1,25 RH	13	44,2	1/4" NPT	22,35	31,75	34,95	23

Type	Pressure (BAR)	Temperature (°C)	RPM
G10C	105	70°	20.000

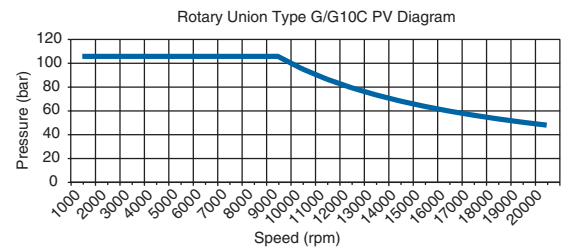

Features and Benefits

- ▶ High pressure bearingless coolant union
- ▶ External bracket mounted
- ▶ Stub rotor mounted directly onto spindle end
- ▶ Compact, precision design for installation flexibility
- ▶ Tungsten carbide seal faces resist wear and thermal shock
- ▶ Optional lipseal for added spindle protection

Custom Unions

Custom designed unions from Johnson-Fluiten are available in both housing-less and housed versions. When the rotary union you require is not shown in the catalogue, Johnson-Fluiten's team of engineers are ready to design and manufacture a custom union for your specific application.

Figure 1

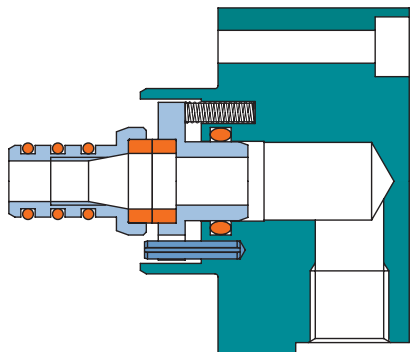

Figure 2

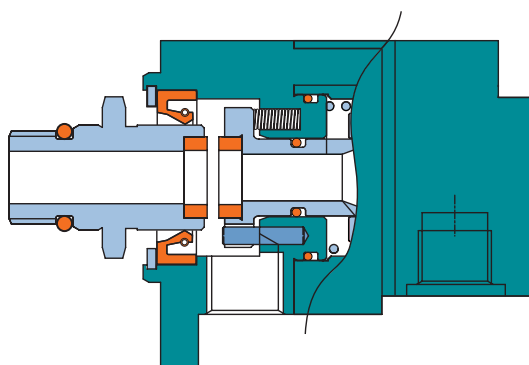

Figure 3

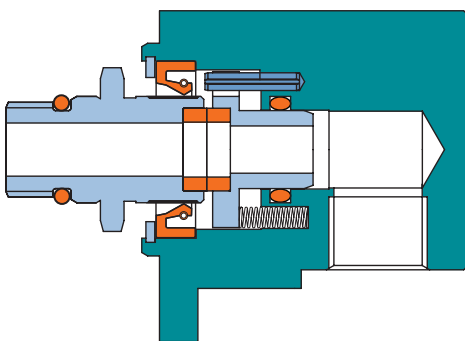

Figure 4

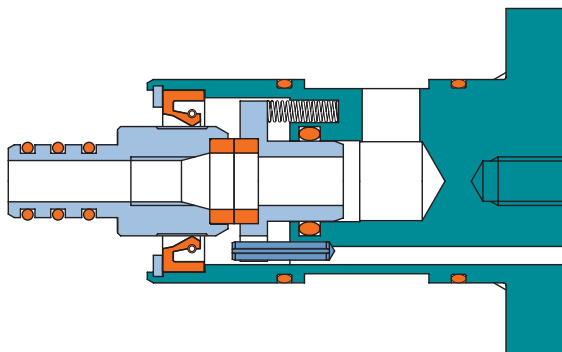

Figure 5

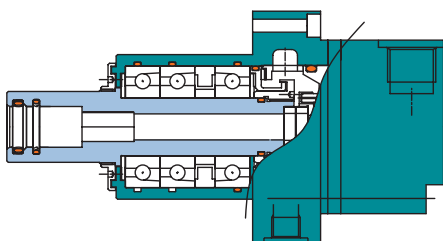
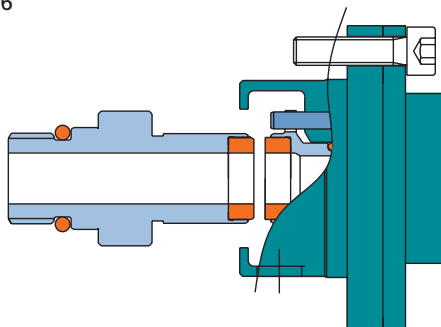

Figure 6



Multi-Passage

G2M



G4M



G5M

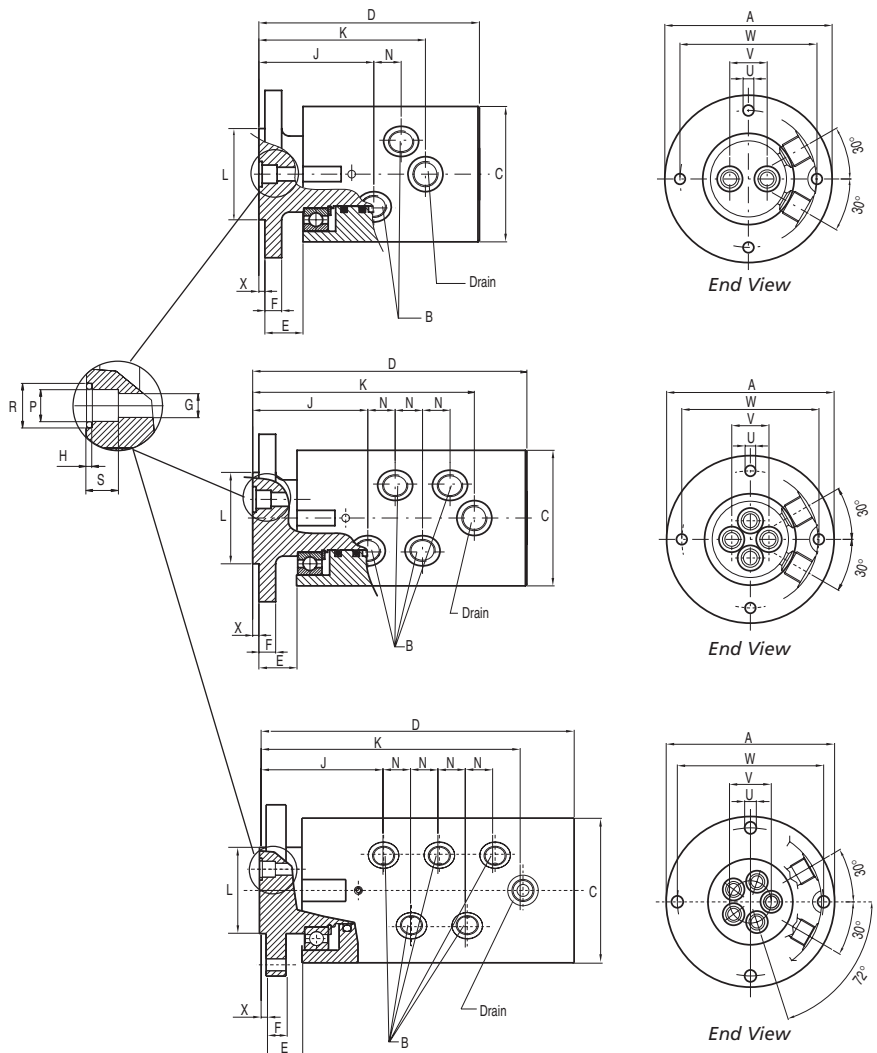

Type	A	B	C	D	E	F	G	H	J	K	L*	N	P	R	S	U	V	W	X
G2M009001494	110	3/8" BSP	89	145	25	11	9	2	76	110	60	18	12	17	12	7	25	90	4
G2M012002385	130	1/2" BSP	108	158	25	14	12	2	81	123	75	23	15	20	15	9	29	110	4
G4M009001454	110	3/8" BSP	89	180	25	11	9	2	76	146	60	18	12	17	12	7	25	90	4
G4M012003608	130	1/2" BSP	108	202	25	14	12	2	81	169	75	23	15	20	15	9	29	110	4
G5M009015044	129	3/8" BSP	109	237	27	15	9	2	94	199	65	21	12	17	12	9	32	112	5

Inter-passage leakage may occur, check compatibility of different fluids.

* L tolerance = h6

Fluid	Pressure (BAR)	Temperature (°C)	RPM
Air	10	90	100
Hydraulic Oil	60	90	100
	250	90	10

Features and Benefits

- ▶ Multi-passage rotary unions for air and oil
- ▶ Precision ball bearings are lubricated for life
- ▶ Proprietary "slide" seal provides long life and dry-running
- ▶ Heat-treated (hardened) stainless steel rotor
- ▶ Drain holes can be connected to a drain line
- ▶ Designed for multi-station index tables

Multi-Purpose

G2M019003818

Fluid	Pressure (BAR)	Temperature (°C)	RPM
Air	10	90	100
Hydraulic Oil	60	90	100
	250	90	10

Inter-passage leakage may occur, check compatibility of different fluids.

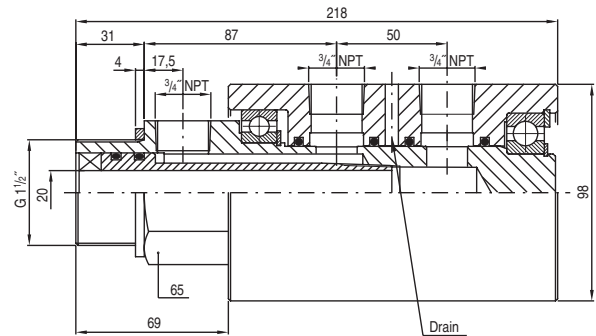

Features and Benefits

- ▶ Two-passage rotary union for air and oil
- ▶ Precision ball bearings are lubricated for life
- ▶ Heat-treated (hardened) stainless steel rotor
- ▶ Drain holes can be connected to a drain line
- ▶ Anodised aluminum body

G/5007/0004

Fluid	Pressure (BAR)	Temperature (°C)	RPM
Air	10	120	1.500
Hydraulic Oil	70	120	1.500

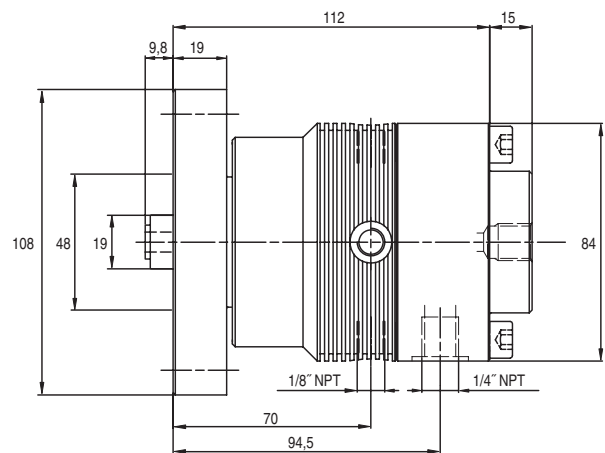

Features and Benefits

- ▶ High-speed two-passage rotary union for air, hydraulic oil, and coolant
- ▶ Unique seal design prevents "accidental" leakage when both passages are pressurised
- ▶ Mechanical seal provides long life and positive sealing
- ▶ High precision ball bearings are lubricated for life
- ▶ Heat-treated (hardened) stainless steel rotor
- ▶ Drain holes can be connected to a drain line

Recommendations

Installation and operation recommendations

Type G rotary unions are high-precision components that provide smooth running operation at high speeds. Due to the precise manufacturing tolerances, these unions require care during installation and maintenance.

Installation instructions are available online at www.coolantunion.com or from your local Kadant Johnson sales office.

Flexible hose

To ensure free movement of the union and elimination of side loading, the proper installation, type, and length of flexible hose should be used. Kadant Johnson recommends SAE 100R1 Type AT single-braid hose. The minimum length of hose is 300 mm for a one-piece installation.

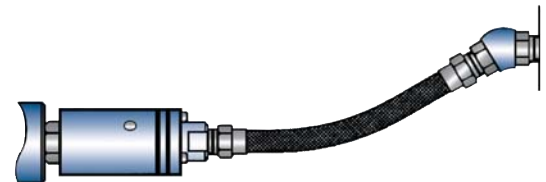

Hose should be a minimum of 300 mm long.

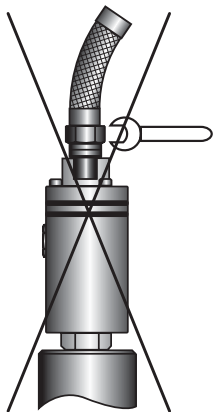

No

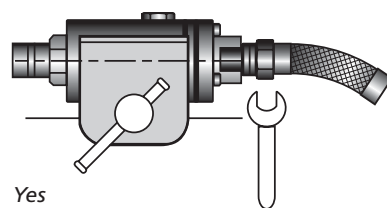

Yes

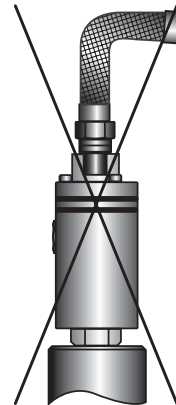

No

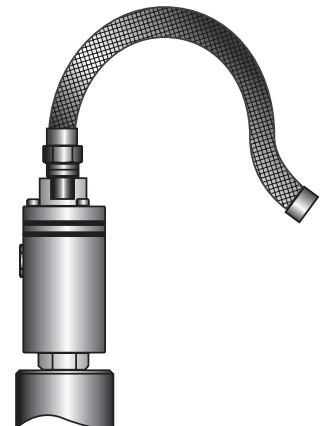

Yes

Lubrication

The seal faces in all Type G rotary unions are lubricated by the media (coolant, hydraulic oil, etc.) passing through the union. The Auto-Off™ seal device found in the GX, GZ, and G5050 unions permits dry running. All ball bearings are lubricated for life and require no additional lubrication.

Filtration

It is important to follow the filtration requirements recommended by the machinery OEM. Type G unions do not require additional filtration other than what is recommended for the coolant pumping system.

Guarantee

Type G unions are tested prior to shipment and are warranted against manufacturing defects for 12 months. Kadant Johnson's global sales and service network stands behind its products and provides support to more than 150 countries worldwide.

Local Assistance On A Worldwide Basis

Many suppliers have made a commitment to the international marketplace. But few have taken that commitment as far as Kadant Johnson. To assure product availability wherever it's needed, Kadant Johnson joints, syphons, and related equipment are manufactured in Asia, Europe, North America, and South America.

Because knowledgeable advice and prompt service are as important as the products, Kadant Johnson has factory-authorized representatives in nearly 150 countries. So no matter where you are, Kadant Johnson products, service, and assistance are nearby.

MANUFACTURING LOCATIONS



805 Wood Street
Three Rivers, MI 49093 USA
tel: +1 269 278 1715
fax: +1 269 279 5980



Nijverheidslaan 23-25
1380 AB Weesp, The Netherlands
tel: +31 294 494200
fax: +31 294 431359



Rua Miguel Nelson Bechara, 297
02712-130, São Paulo, SP, Brazil
tel: +55 11 3932 7877
fax: +55 11 3931 4043



Wuxi National Hi-Tech Industrial Development Zone
Wuxi City, Jiangsu Province, China
tel: +86 510 85212218
fax: +86 510 85212038

Joint Venture Sales Office



JOHNSON-FLUITEN, S.R.L.
Via Newton, 21
20016 Pero, Milano (Italy)
tel: +39 02 3394091
fax: +39 02 33940950
www.johnson-fluiten.com

KADANT
AN ACCENT ON INNOVATION

Kadant is a leading global supplier of products and services that improve productivity and quality in paper production and other process industries. For the nearest location and contact, visit our Website.

www.kadant.com

Contact us:

JOHNSON-FLUITEN S.R.L.
Via Newton, 21
20016 Pero (MI) Italia

Tel.: +39-023394091
Fax: +39-0233940950
Email: info@johnson-fluiten.com

G-3003 (Metric EN) 09/2009
replaces G-3002r (ENG Metric)
© 2009 Kadant Inc.